



X40 SERIES 40 WATT HIGH VOLTAGE DC/DC CONVERTERS

FEATURES

- ▶ Customer Selects Output Voltage
- ▶ Ultra Wide Input Ranges
(9-36Vdc, 20-60Vdc, 36-72Vdc)
- ▶ Efficiency 86% (typ.)
- ▶ Independently Isolated Outputs
- ▶ Six-Sided Shielded Case
- ▶ Remote On/Off Control
- ▶ Continuous Short Circuit Protection



The X40 Series of DC/DC converters accepts ultra wide input ranges of 9-36 Vdc, 20-60 Vdc and 36-72 Vdc. Outputs are independently isolated. In the case of duals, up to 32 watts may be taken from either output. All models will tolerate a short circuit indefinitely. Also included is a Pi input filter and remote on/off.

ELECTRICAL SPECIFICATIONS

Voltage Accuracy +/- 1%
 Line Regulation +/- 0.1%
 Load Regulation +/- 0.3%
 Output Ripple < 0.4% P-P

Input Filter Pi Network
 Efficiency 86% (typ.)
 Short Circuit Protection Continuous
 Switching Frequency 120 kHz
 Isolation (Input-Output(1)-Output(2)-Case) 1000 Vdc
 Input / Output Capacitance < 100pF

GENERAL SPECIFICATIONS

Temp. Stability +/- 0.02%/°C
 Temp. (Operating, Case) -45 to +85°C
 Temp. (Storage) -55 to +100°C

Logic Shutdown Logic 0 (on)
 EMI/RFI Six Sided Shield
 Derating None
 Cooling Free-Air Convection

PHYSICAL SPECIFICATIONS

Dimensions 2.57 x 4.57 x 0.84 inches
 Weight 12.7 Oz

Case Material Black Coated Metal
 (With Non-Conductive Base Plate)



X40 SERIES 40 WATT HIGH VOLTAGE DC/DC CONVERTERS

REPRESENTATIVE MODEL LISTING

OUTPUT SPECS				MODEL NUMBER / INPUT RANGE					
VOLTAGE		CURRENT		9-36VDC		20-60VDC		36-72VDC	
OUT #1	OUT #2	OUT #1	OUT #2	Non-RoHS	RoHS	Non-RoHS	RoHS	Non-RoHS	RoHS
48 Vdc	-	833 mA	-	X40-48	X40-48/Y	X40-48/B	X40-48/B/Y	X40-48/C	X40-48/C/Y
48 Vdc	48Vdc	416 mA	416 mA	X40-48/48	X40-48/48/Y	X40-48/48/B	X40-48/48/B/Y	X40-48/48/C	X40-48/48/C/Y
50 Vdc	-	800 mA	-	X40-50	X40-50/Y	X40-50/B	X40-50/B/Y	X40-50/C	X40-50/C/Y
50Vdc	50 Vdc	400 mA	400 mA	X40-50/50	X40-50/50/Y	X40-50/50/B	X40-50/50/B/Y	X40-50/50/C	X40-50/50/C/Y
75Vdc	-	533 mA	-	X40-75	X40-75/Y	X40-75/B	X40-75/B/Y	X40-75/C	X40-75/C/Y
75 Vdc	75 Vdc	266 mA	266 mA	X40-75/75	X40-75/75/Y	X40-75/75/B	X40-75/75/B/Y	X40-75/75/C	X40-75/75/C/Y
100 Vdc	-	400 mA	-	X40-100	X40-100/Y	X40-100/B	X40-100/B/Y	X40-100/C	X40-100/C/Y
100 Vdc	100Vdc	200 mA	200 mA	X40-100/100	X40-100/100/Y	X40-100/100/B	X40-100/100/B/Y	X40-100/100/C	X40-100/100/C/Y
150 Vdc	-	266 mA	-	X40-150	X40-150/Y	X40-150/B	X40-150/B/Y	X40-150/C	X40-150/C/Y
150 Vdc	150 Vdc	133 mA	133 mA	X40-150/150	X40-150/150/Y	X40-150/150/B	X40-150/150/B/Y	X40-150/150/C	X40-150/150/C/Y
200 Vdc	-	200 mA	-	X40-200	X40-200/Y	X40-200/B	X40-200/B/Y	X40-200/C	X40-200/C/Y
200Vdc	200Vdc	100 mA	100 mA	X40-200/200	X40-200/200/Y	X40-200/200/B	X40-200/200/B/Y	X40-200/200/C	X40-200/200/C/Y
300 Vdc	-	133 mA	-	X40-300	X40-300/Y	X40-300/B	X40-300/B/Y	X40-300/C	X40-300/C/Y
300 Vdc	300 Vdc	66 mA	66 mA	X40-300/300	X40-300/300/Y	X40-300/300/B	X40-300/300/B/Y	X40-300/300/C	X40-300/300/C/Y
400Vdc	-	100 mA	-	X40-400	X40-400/Y	X40-400/B	X40-400/B/Y	X40-400/C	X40-400/C/Y
400Vdc	400 Vdc	50 mA	50 mA	X40-400/400	X40-400/400/Y	X40-400/400/B	X40-400/400/B/Y	X40-400/400/C	X40-400/400/C/Y
500 Vdc	-	80 mA	-	X40-500	X40-500/Y	X40-500/B	X40-500/B/Y	X40-500/C	X40-500/C/Y
500 Vdc	500Vdc	40 mA	40 mA	X40-500/500	X40-500/500/Y	X40-500/500/B	X40-500/500/B/Y	X40-500/500/C	X40-500/500/C/Y

X40-110/110/B/Y

Product Family

Total Output Power

Out 1

Out 2

/Y Compliance

Alternate Input Range
/B 20Vdc - 60Vdc
/C 36Vdc - 72Vdc

Customer Selects Output Voltage

The X40 Series are designed such that the customer may order any output voltage from 48Vdc to 500Vdc at no additional charge.



X40 SERIES 40 WATT HIGH VOLTAGE DC/DC CONVERTERS

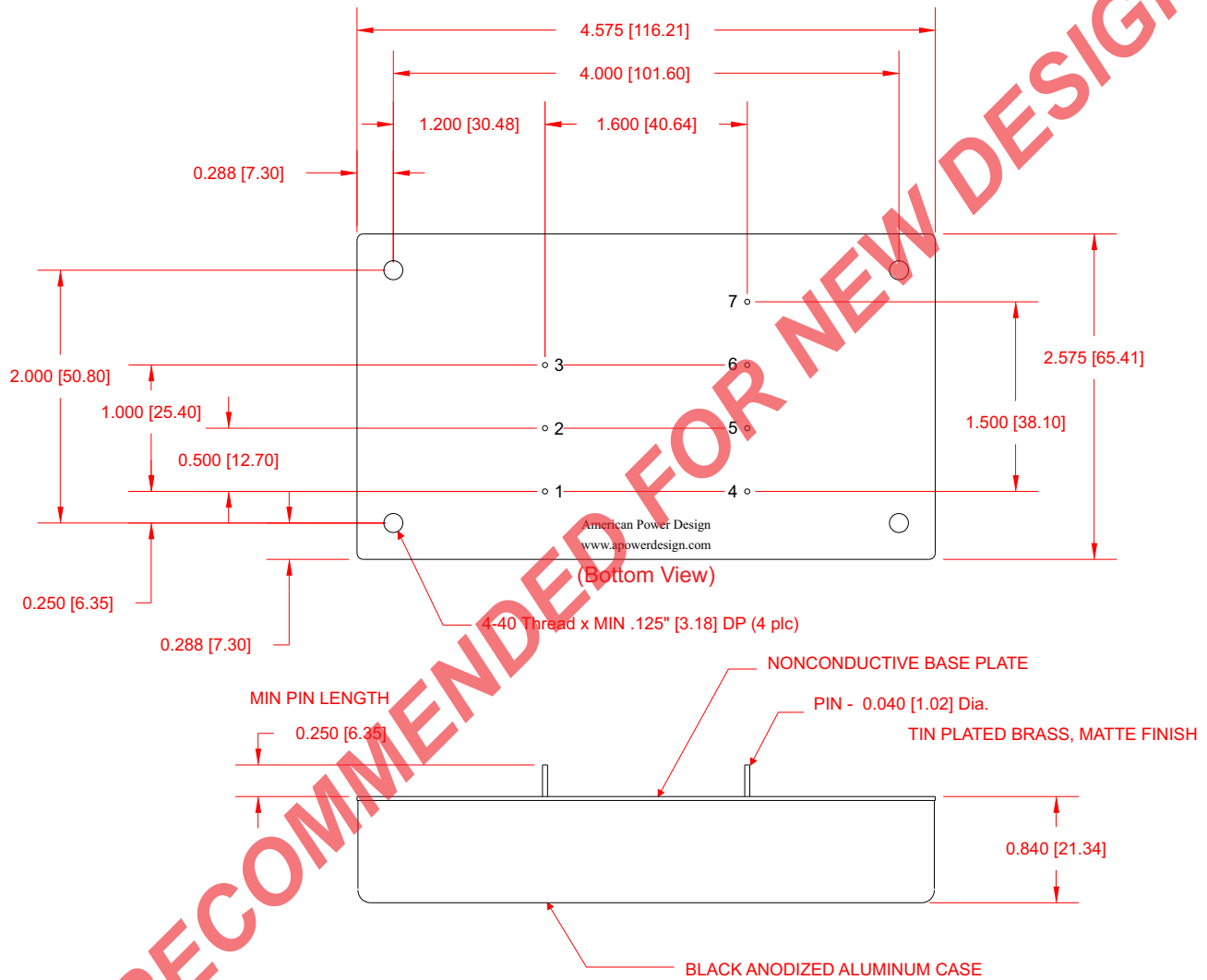

PIN #	SINGLE	DUAL
1	- Input	- Input
2	On/Off	On/Off
3	+ Input	+ Input
4	No Pin	+ Output 2
5	No Pin	- Output 2
6	- Output 1	- Output 1
7	+ Output 1	+ Output 1

Dimensions are in Inches
 [Metric equivalents in brackets]



X40 SERIES 40 WATT HIGH VOLTAGE DC/DC CONVERTERS

APPLICATION NOTES

INPUT AND OUTPUT IMPEDANCE

The X40 Series of power converters have been designed to be stable with no external capacitors when used in low inductance input and output circuits. However, in some applications, the inductance associated with the distribution from the power source to the input of the converter can affect the stability of the converter. The addition of a 100 μF electrolytic capacitor with an ESR $< 1 \text{ Ohm}$ across the input helps ensure stability of the converter. In many applications, the user has to use decoupling capacitance at the load.

SHORT CIRCUIT PROTECTION

The X40 Series is equipped with short circuit protection. The converter will fold-back the input power whenever a short circuit is applied to its output and automatically recover after the overload condition is removed.

ISOLATION

The output(s) of the X40 Series is galvanically isolated from both the input and case, capacitance is $< 100 \text{ pF}$ and resistance is $> 10 \text{ G Ohm}$.

In the case of dual's, the outputs are independently isolated from one another as well as the input and case.

RIPPLE AND NOISE

Figure below shows a typical output voltage ripple waveform, measured at full rated load current with no additional output filtering. External low ESR capacitors may be added across output to further reduce ripple.

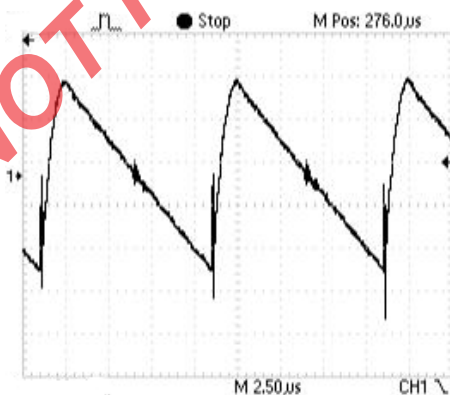

STARTUP TRANSIENT

Figure below shows a typical output voltage during turn-on, measured at 20% load current with no additional output filtering.

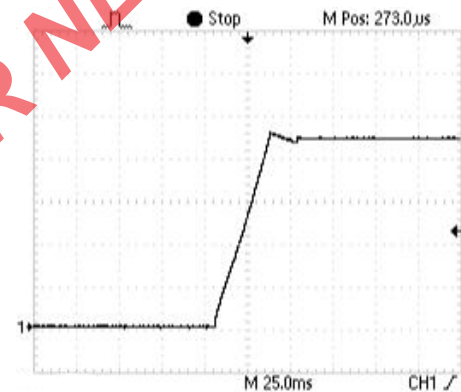
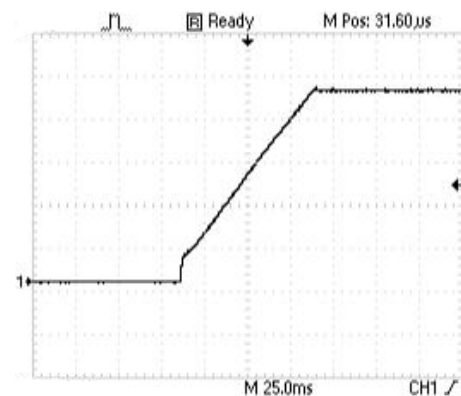

Figure below shows a typical output voltage during turn-on, measured at full rated load current with no additional output filtering.





X40 SERIES 40 WATT HIGH VOLTAGE DC/DC CONVERTERS

APPLICATION NOTES

INRUSH CURRENT

The inrush current of the X40 Series has been kept as low as possible. However, a series resistor may be inserted in the input line to limit this current further.

LOAD TRANSIENT

Figure below shows a typical output voltage response, measured during a transition from full rated load current to 20% load current with no additional output filtering.

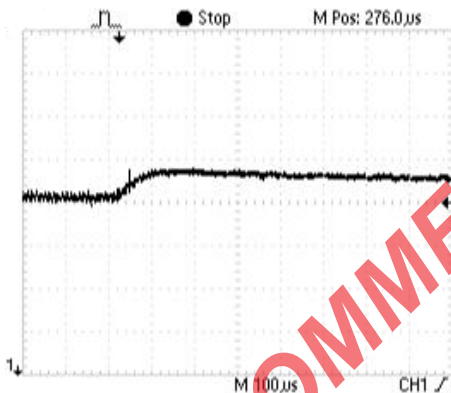
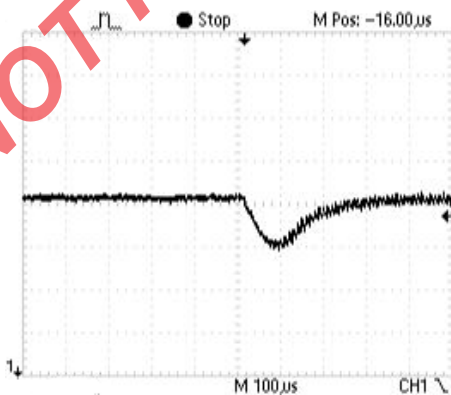

Figure below shows a typical output voltage response, measured during a transition from 20% load current to full rated load current with no additional output filtering.



REMOTE ON/OFF CONTROL

The On/Off control pin allows the user to shut down the converter mechanically or logically using a relay or a TTL or CMOS logic signal.

Connect Remote On/Off pin to -Input when not in use to ensure proper operation.

Resistor R1 can be calculated by:

$$R1 = \frac{(+ \text{ Input} - 5)}{1\text{mA}}$$

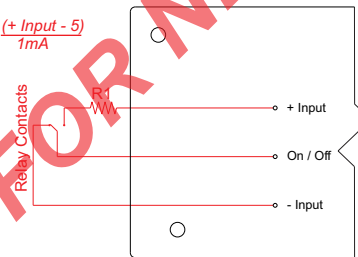

Converter Off: $V_c > 3V_{dc}$
 Converter On: $V_c < 1.5V_{dc}$

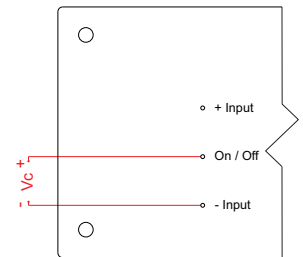

NOTE:
 Do not exceed 6Vdc on remote On/Off, otherwise, the supply may be permanently damaged.

OUTPUT CONFIGURATIONS

Due to the unique independently isolated outputs of the X40 series both Output #1 and Output #2 may be connected in a wide variety configurations. The Figures below are some examples.

Dual Positive Output

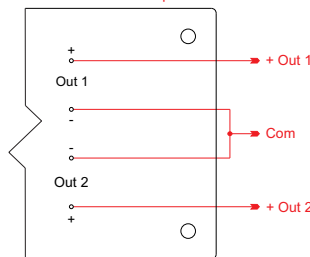

Dual Negative Output

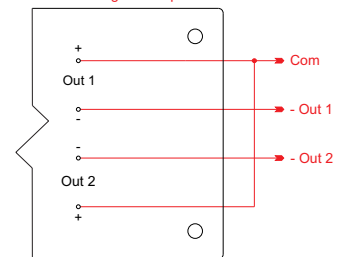

Bipolar Output

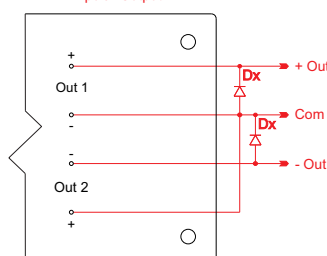

Outputs > 500Vdc

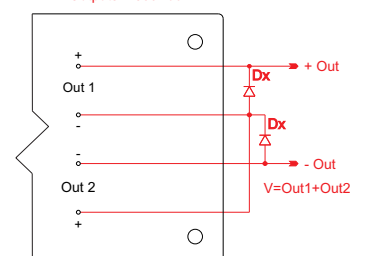

NOTE:
 The ratings of Dx should be 1.5 times the maximum current and voltage expected in each branch.



X40 SERIES 40 WATT HIGH VOLTAGE DC/DC CONVERTERS

APPLICATION NOTES

CONNECTION IN PARALLEL

The figure below shows how to connect several single output units with equal nominal output voltage in parallel.

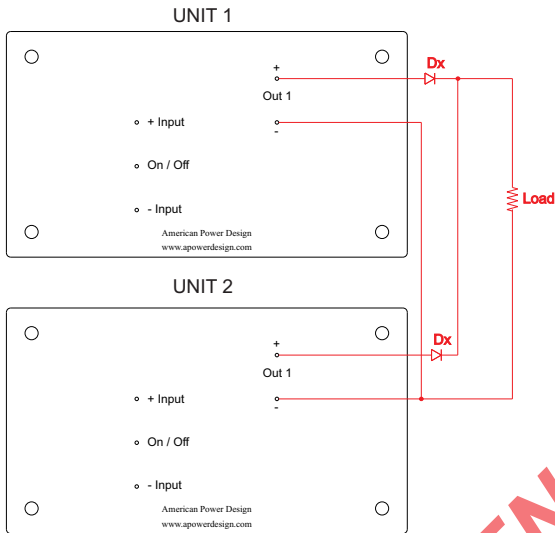

NOTE:
The ratings of Dx should be 1.5 times the maximum current and voltage expected in each branch.

The figure below show how to connect several dual output units with equal nominal output voltage in parallel.

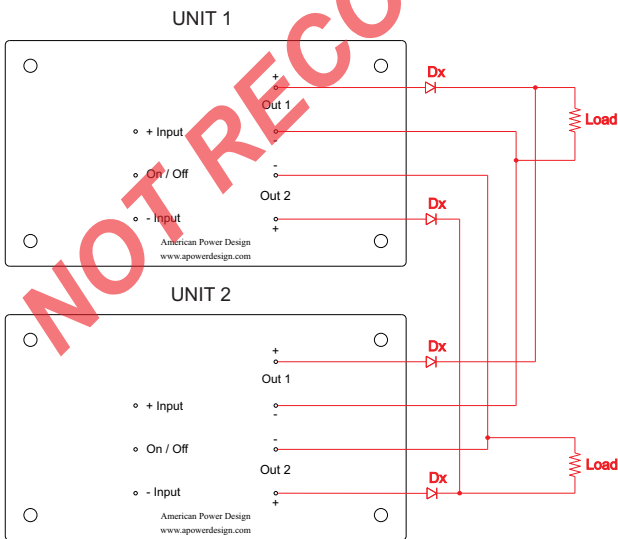

NOTE:
The ratings of Dx should be 1.5 times the maximum current and voltage expected in each branch.

CONNECTION IN SERIES

When connecting units in series, the highest achieved output voltage should remain below the rated isolation voltage.

Figure below shows how to connect multiple single output units in series with the use of shunt diodes.

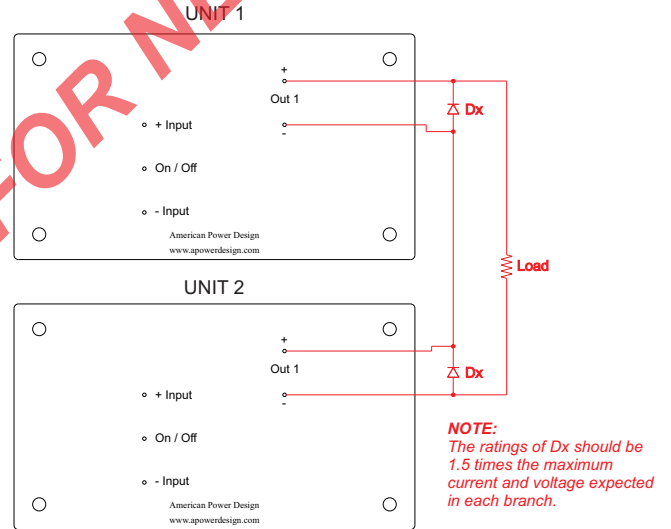

NOTE:
The ratings of Dx should be 1.5 times the maximum current and voltage expected in each branch.

Figure below shows how to connect multiple dual output units in series with the use of shunt diodes.

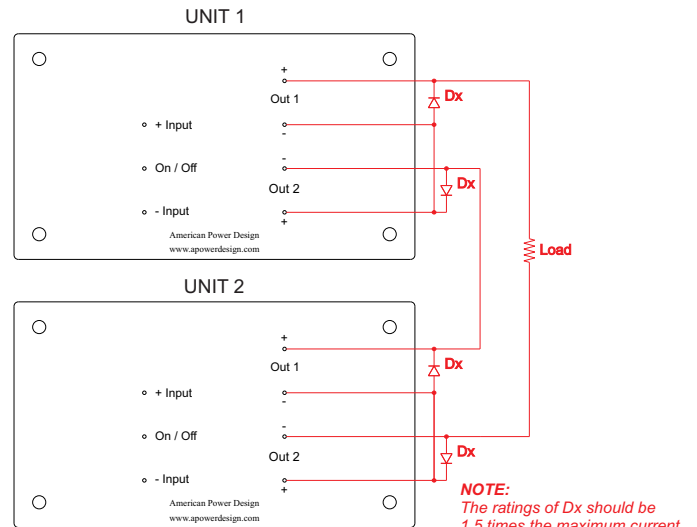

NOTE:
The ratings of Dx should be 1.5 times the maximum current and voltage expected in each branch.



X40 SERIES 40 WATT HIGH VOLTAGE DC/DC CONVERTERS

APPLICATION NOTES

CLEANING AGENTS

In order to avoid possible damage, any penetration of cleaning fluids must be prevented, since the power supplies are not hermetically sealed.

NUCLEAR AND MEDICAL APPLICATIONS

American Power Design products are not designed, intended for use in, or authorized for use as critical components in life support systems, equipment used in hazardous environments, or nuclear control systems without the express written consent of American Power Design, Inc.

TECHNICAL REVISIONS

The appearance of products, including safety agency certifications pictured on labels, may change depending on the date manufactured. Specifications are subject to change without notice.

SAFETY REQUIREMENTS

The converters are designed to meet North American and International safety regulatory requirements per UL 60950-1/CSA 22.2 No. 60950-1-07 Second Edition, IEC 60950-1:2005, and EN 60950-1:2006. Basic Insulation is provided between input and output. To comply with safety agencies requirements, an input line fuse must be used external to the converter. The table below provides the recommended fuse rating for use with this family of products.

Input Voltage Range	Fuse Rating
9-36Vdc	7 A
20-60Vdc	3.5 A
36-72Vdc	2 A

If one input fuse is used for a group of modules, the maximum fuse rating should not exceed 20A.

WARRANTY

All products manufactured by American Power Design, Inc. (APD) are warranted to be free of defects due to material or workmanship for a period of one year from date of shipment. At our option, APD will repair or replace any non-conforming product.

APD expressly disclaims any liability for consequential or incidental damages resulting from the use or misuse of its products by the purchaser or others.

This warranty is in lieu of all warranties expressed or implied, including the warranties of merchantability. No other warranties, obligations, or liabilities are expressed or implied.

All products being returned for repair require a return material authorization(RMA) assigned by APD prior to return shipment.