

OUTPUT VOLTAGES FROM 100V TO 2000VDC

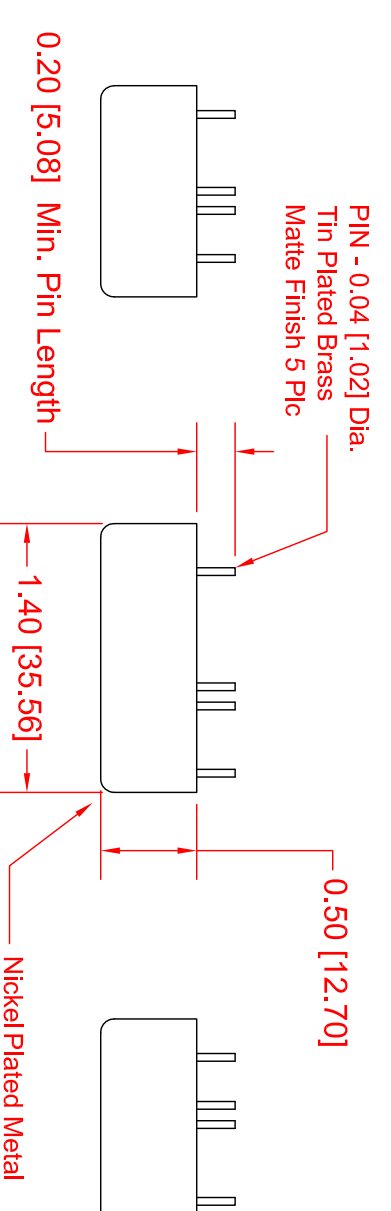

PIN #	FUNCTION
1	+ INPUT
2	GND
3	CONTROL / PROGRAMMING VOLTAGE
4	HV OUTPUT
5	CASE GND

OUTPUT VOLTAGES FROM 2100V TO 4000VDC

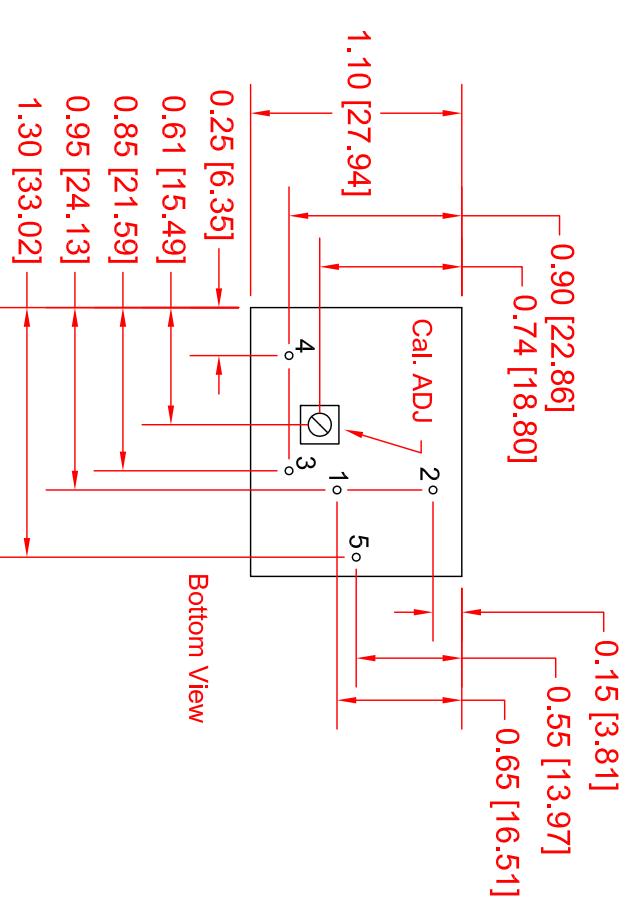
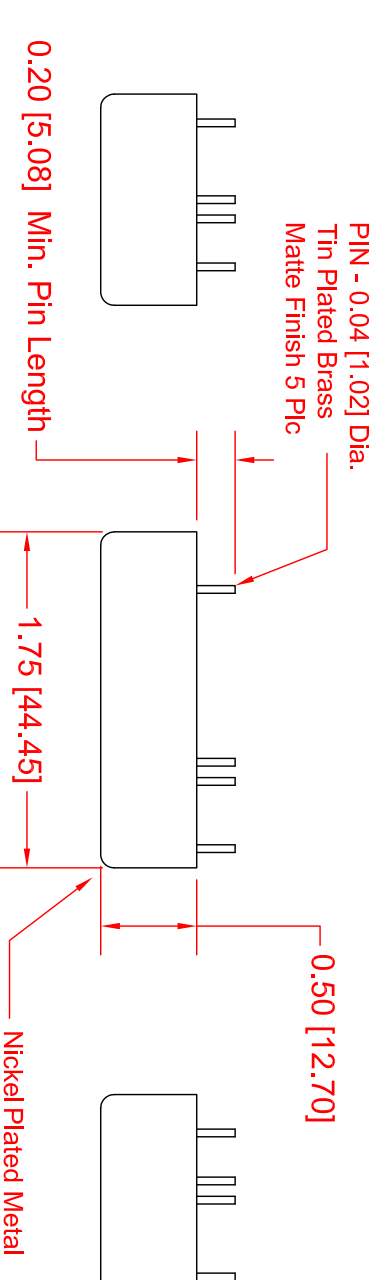
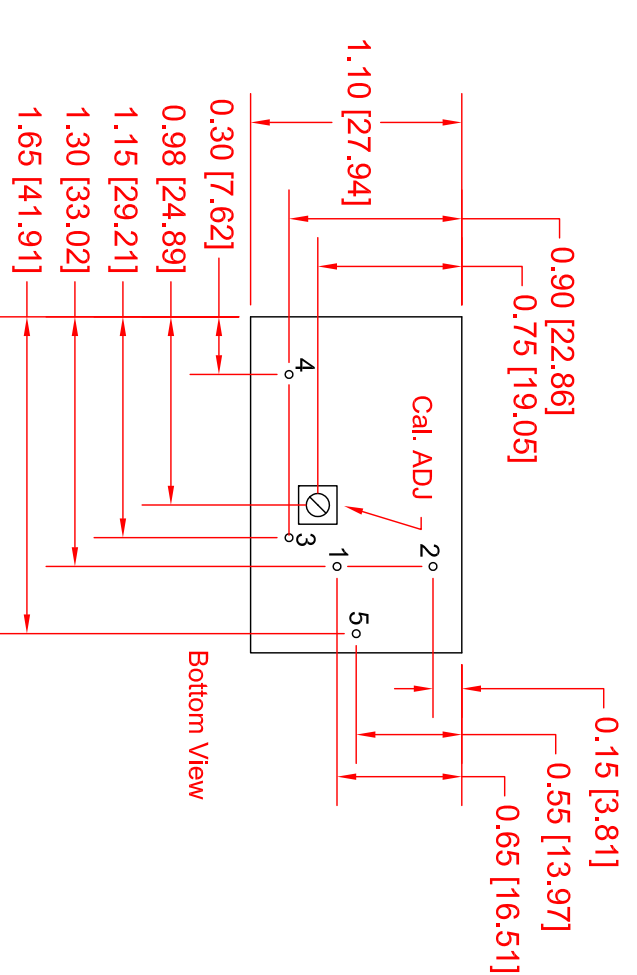

PIN #	FUNCTION
1	+ INPUT
2	GND
3	CONTROL / PROGRAMMING VOLTAGE
4	HV OUTPUT
5	CASE GND

OUTPUT VOLTAGES FROM 4100V TO 8000VDC

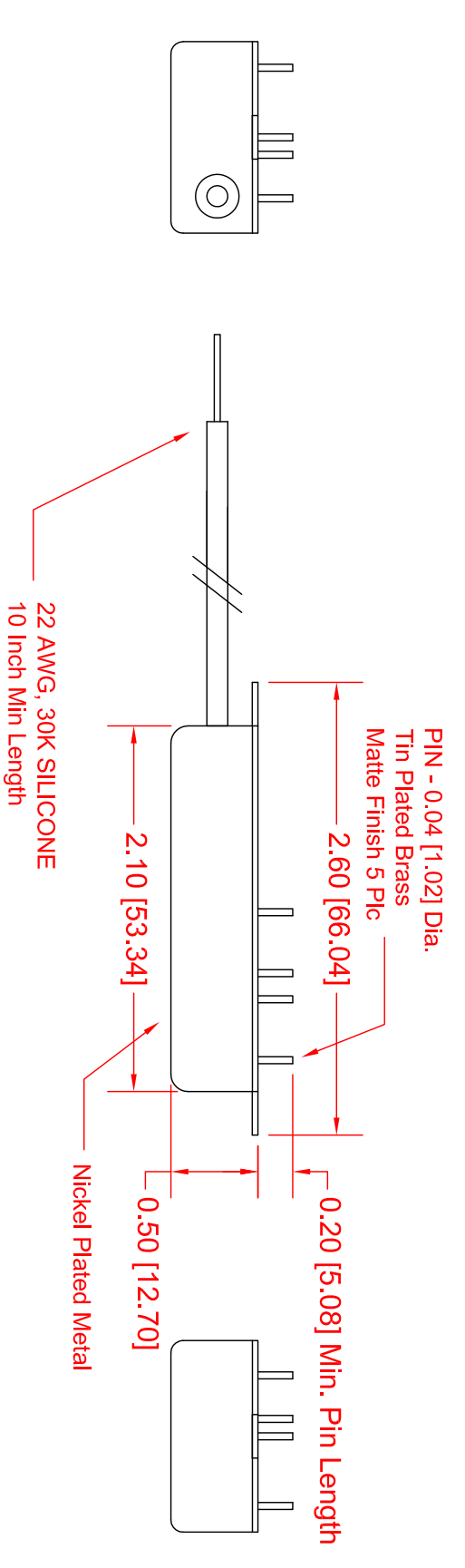
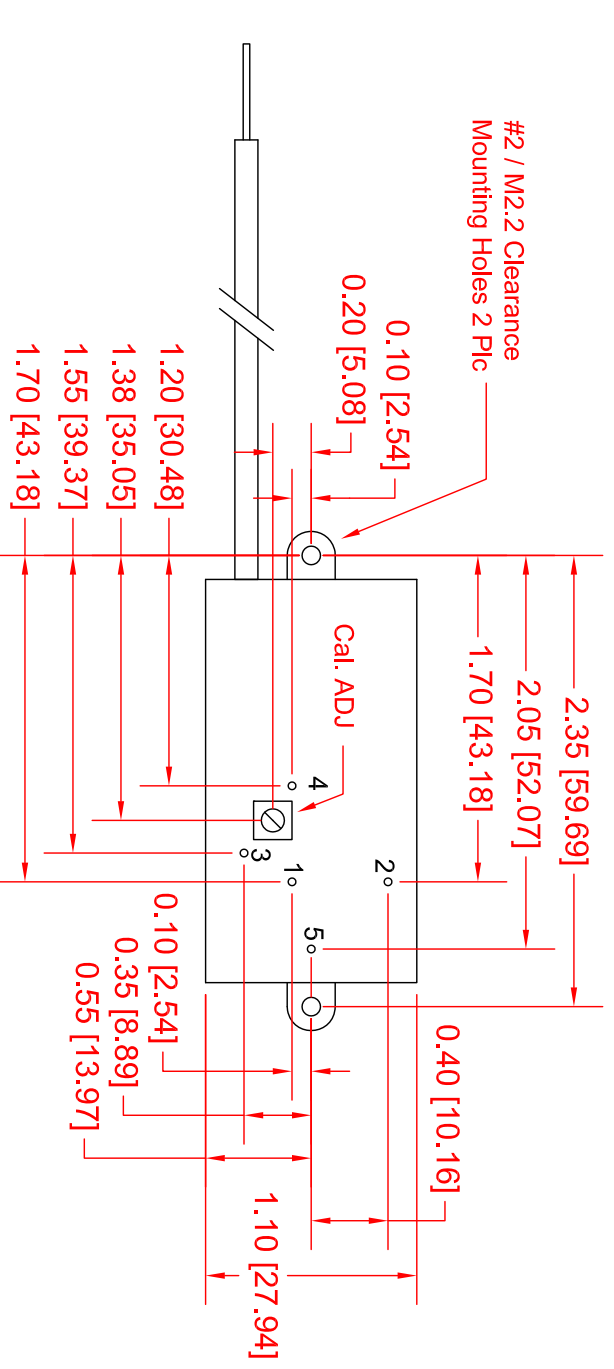

PIN #	FUNCTION
1	+ INPUT
2	GND
3	CONTROL / PROGRAMMING VOLTAGE
4	HV RETURN
5	CASE GND